

The DuraSeal™

Double Block & Bleed Plug Valve



The DuraSeal™ Double Block & Bleed Plug Valve

The DuraSeal™ is a mechanically seated, non-lubricated expanding plug valve that provides a provable bubble tight seal for your most critical isolation applications. Available in both reduced and full-bore options, the DuraSeal™ employs industry proven technology in tandem with robust product innovations to provide consistent DBB/DIB-1 isolation performance. Standing in support of the product lies a world class quality program, and dedicated technical and sales teams ready to support your organization's project needs.

The DuraSeal™ meets the following product requirements:

- API 6D, DBB & DIB-1 monogrammed
- API 6FA (Firesafe)
- API 591 (Destructive)
- ISO 15848-1 by request (Emissions)
- PED/CE by request
- CRN (Canada) certified
- TSG (China) certified
- Designed, assembled and tested in an ISO 9001 certified/API Q1 compliant facility



Table of Contents

Company History	2
How the DuraSeal™ Valve Works	3
DuraSeal™ Valve - Internal View	4
Operation/Applications	5
Standard Materials of Construction D700 Reduced & D600 Full Bore	6
Preferred Mounting Positions	7
D700 Series Reduced Bore ANSI 150 - Gear Operated	8
D700 Series Reduced Bore ANSI 300, 600, 900 - Gear Operated	9
D700 Series Handwheel Operated	10
D600 Series FULL BORE ANSI 150 - Gear Operated	11
D600 Series FULL BORE ANSI 300, 600, 900 - Gear Operated	12
Electric Motor Actuation and Extensions	13
D700 & D600 Series ANSI 150 - Flow Coefficients (CV) and Torque & Turns	14
D700 Series ANSI 300/600/900 - Flow Coefficients (CV) and Torque & Turns	15
D600 Series ANSI 300/600/900 - Flow Coefficients (CV) and Torque & Turns	16
Actuator Adaption-Gear Operator Mounting	17
Differential Thermal Relief Systems	18
DTR - Standard Configuration	19
DTR - Line Relieving	20
DTR - Automatic Body Bleed	21



Company History

Since 2005, Franklin Valve has been on a mission to supply the oil & gas industry with a quality product, while also leading the industry in customer service and delivery. In 2014 we moved into our current facility, allowing us to better leverage our large inventory and lean manufacturing practices while expanding on our Engineering and R&D capabilities, all with the goal of better serving customer needs.

As we've grown, our **Value Proposition** has remained the same: Franklin Valve offers the highest value on product quality and customer service while leveraging our large inventories to meet and exceed customer lead times. Franklin Valve is globally distributed, represented and approved with high profile end users and Original Equipment Manufacturers.

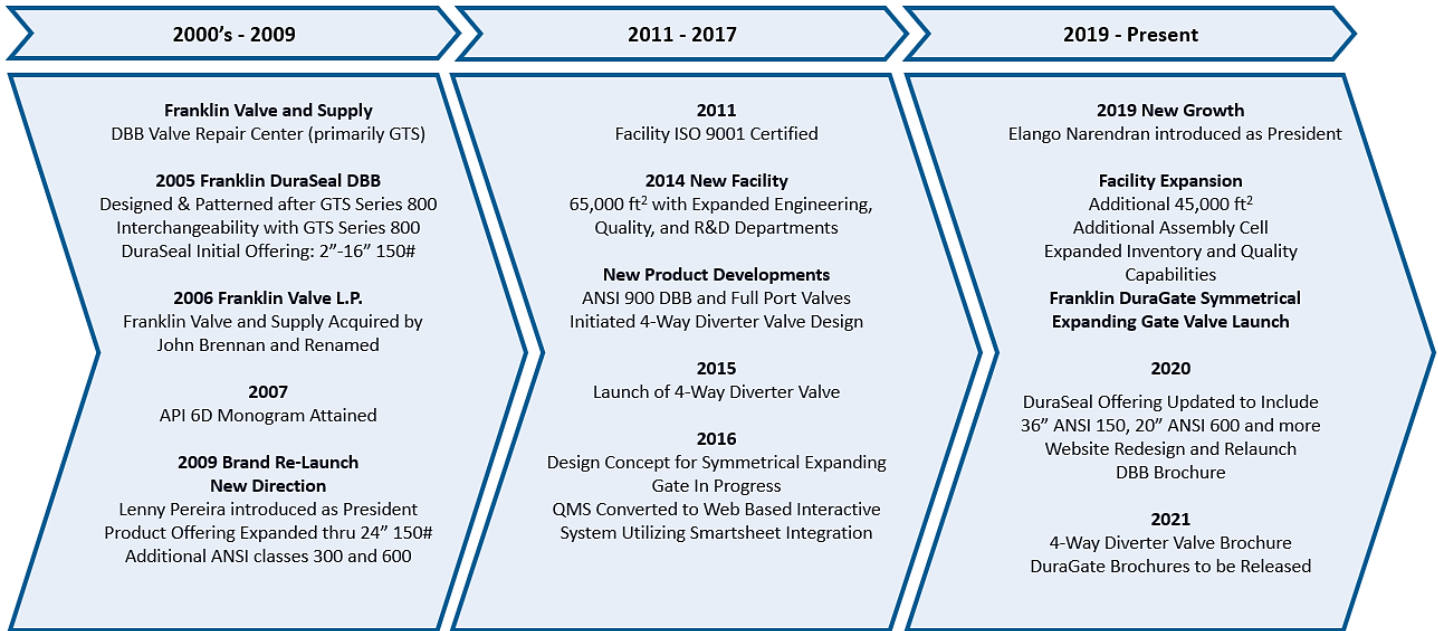

How the DuraSeal™ Valve Works

An Improved Valve with a Proven History

We took an alternative path. Unlike many valve manufacturers who often strip valves in their quest to reduce manufacturing costs, we have taken a proven double block and bleed plug valve and improved its design.

With the DuraSeal™, you get the proven advantages of a valve that has been considered the standard of quality since 1951. To improve the valve's integrity, we have incorporated a superior slip design and more durable body. To improve performance and longevity, we have incorporated a more reliable stem seal design.

In short, the Franklin DuraSeal™ is made to last - not to make a quick sale.

Field Repairable/Interchangeable Parts

Select 700 series DuraSeal™ parts are completely interchangeable with the original 800 Series General Valve Twin Seal™ double block and bleed plug valve. DuraSeal™ components manufactured from superior materials can upgrade existing TwinSeals™ in the field. The DuraSeal™ can be repaired inline after depressurizing and draining the valve without special tools. Simply remove the valve's lower plate or bonnet and replace the slip/seal assemblies from top or bottom of the valve. Further detail on parts interchangeability is available upon request.

Reliable Double Protection Mechanical Seal

The Franklin DuraSeal™ plug valve seals mechanically. During rotation of the plug there is no abrasion or wear between the sealing surfaces. When the slips reach the closed position, they expand firmly into the valve body creating a primary elastomeric and secondary metal-to-metal backup seal. The DuraSeal™ does not require sealant under any circumstance to seal.

Fast Low Torque Operation

The DuraSeal™ can be easily automated using electric actuators. Torque requirements are low. In smaller sizes only two and one quarter turns can fully open or close the valve.

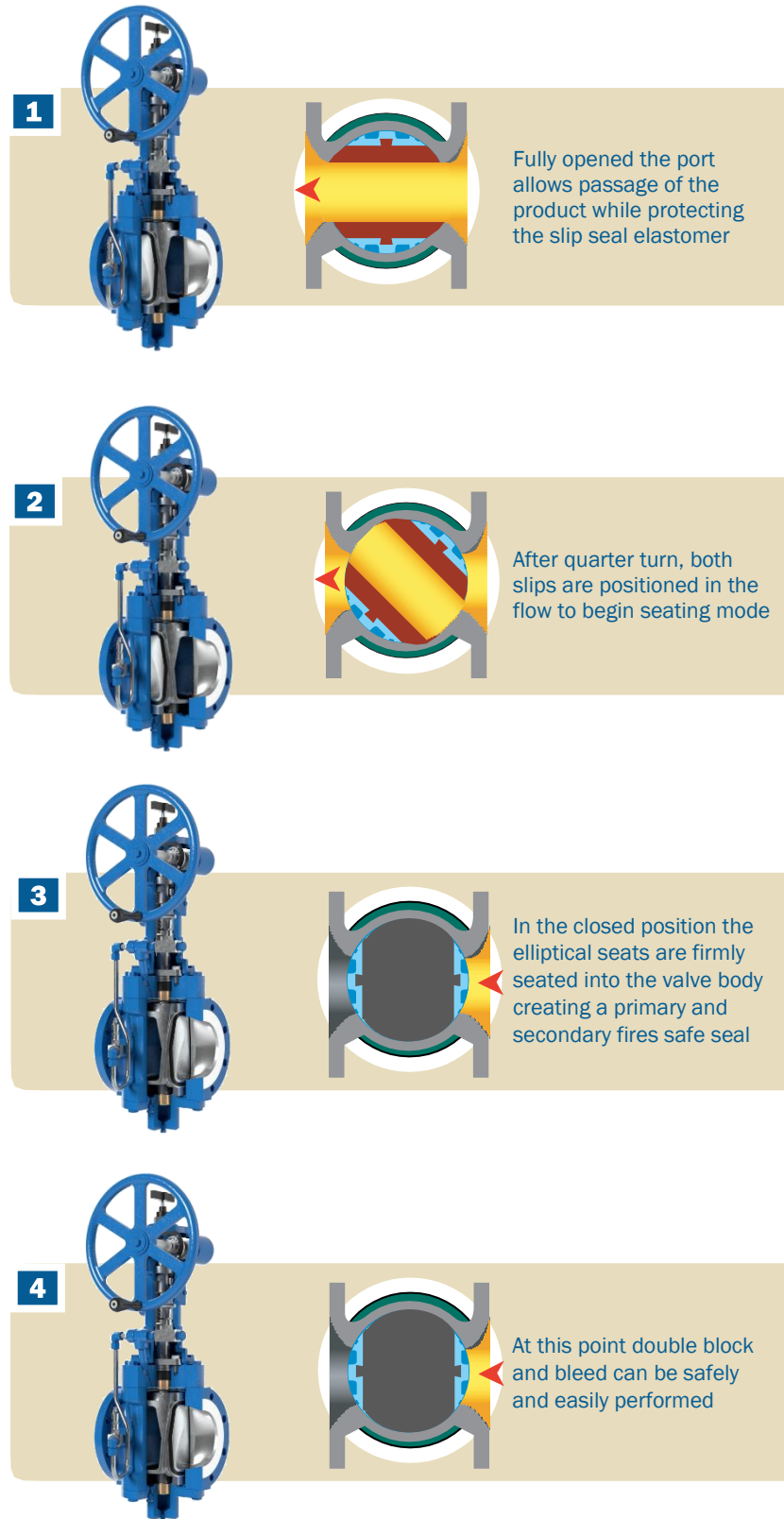

DuraSeal™ Valve Internal View

Easily Automated with Choice of electric Actuators. DuraSeal™ available in wide range of elastomer materials.

Applications

With bubble-tight fire-safe sealing integrity and the ability to double block and bleed from a single valve, the DuraSeal™ is an excellent choice for applications that require frequent isolation and testing of gas or liquids.

- Product manifolds
- Measurement units
- Isolation of processing equipment
- Loading Racks and Tank Isolation

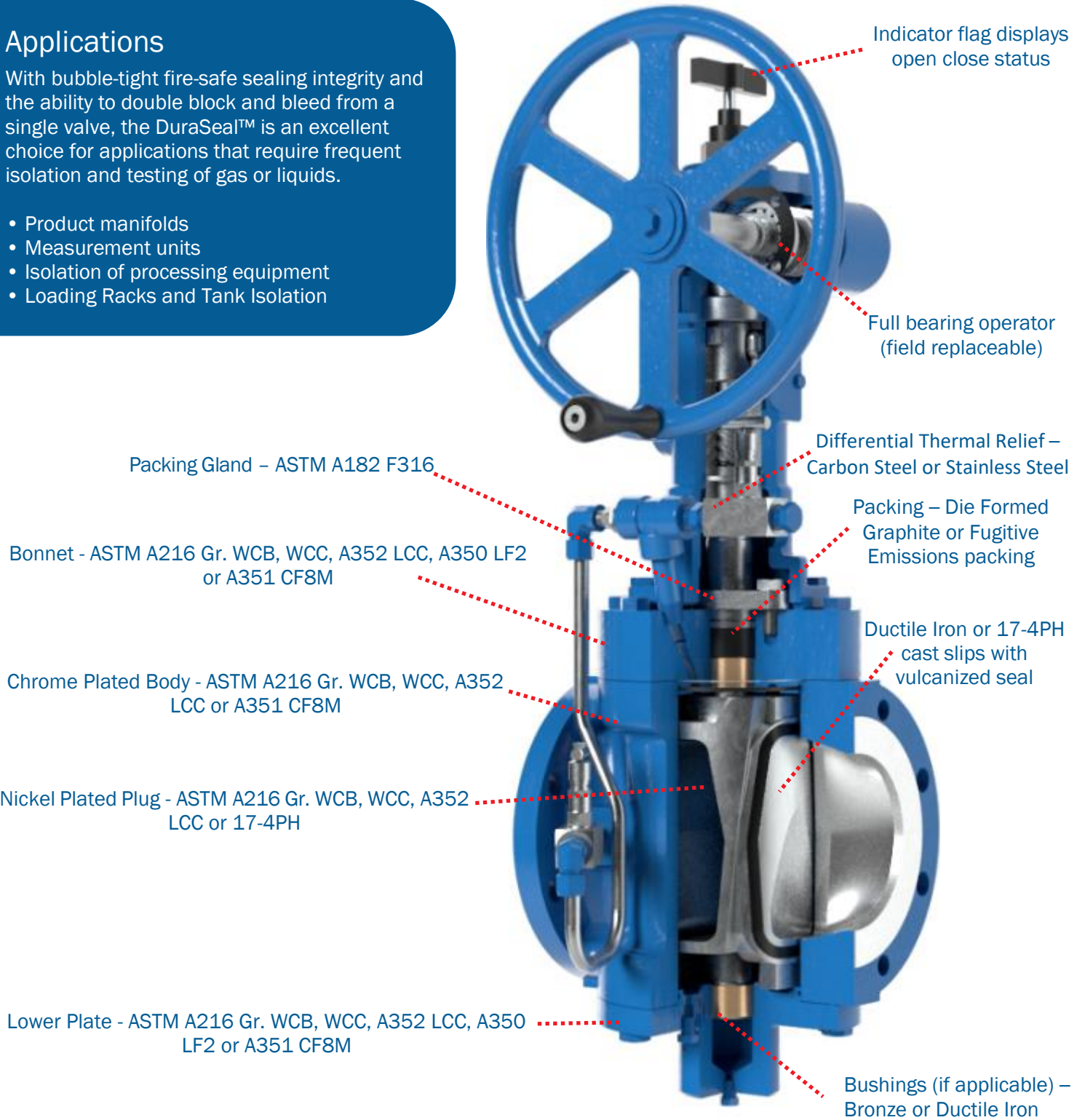

Franklin Valve reserves the right to change trim codes w/o prior notification

Operations and Applications

VALVE OPERATION

Opening the Valve: Turn the hand-wheel counterclockwise. During this operation, the plug is raised while the slips are retracted away from the body. When the slips are fully retracted from the body seating area, the plug is then able to rotate 90 degrees to the fully open position. When the valve is in the fully open position, the slips and slip seals are completely protected from line flow.

Closing the Valve: Turn the hand-wheel clockwise. During this operation, the retracted plug and slips are rotated 90 degrees without body contact. This rotation continues until the slips are positioned over the up- stream and downstream port areas. Continued rotation of hand-wheel mechanically forces the plug down- ward and forces the slips outward to seal firmly against the valve body. This produces a secondary metal to metal seal on both upstream and downstream areas providing double isolation.

APPLICATION NOTES

- **Biofuels Product Isolation:** Secure sealing of Biofuels is critical in protecting the environment. The DuraSeal™ DBB Valve with its verifiable secure shutoff is perfect when process must be contained.
- **Multi-Product Manifolds:** Some pipeline manifolds need to flow various products (e.g. diesel, jet fuel, gasoline, etc.) reliably and without contaminating one another. This DuraSeal™ DBB Valve is used to provide positive shut off and zero leakage to prevent cross contamination.
- **Prover Loops:** In prover loops, the calibration of flow meters requires that every valve in the system must have zero leak rates. Any leak could mean an error in calibration. The DuraSeal™ DBB Valve is used to ensure that when the valves in the system are closed, they are leak tight.
- **Custody Transfer Units:** Transfer of valuable media relies on accurate measurement of product. The DuraSeal™ DBB Valve provides secure tight shutoff ensuring that the transfer is accurate.
- **Terminals:** Loading and unloading tanker vessels requires positive sealing in order to prevent spillage into the water. The DuraSeal™ DBB Valve provides such positive sealing and is the most reliable in the market.
- **Tank Farms (Oil Depots):** Valves used for tank isolation needs to work reliably with zero leak rate. These valves are also operated frequently. The DuraSeal™ DBB Valve provides a reliable long-term high integrity seal designed for frequent use with verifiable zero leak.
- **Aviation Fueling Systems:** Fuel hydrants at airports need to allow for quick maintenance, repair, leak locating and testing. This requires a valve that can close quickly and positively seal off the relevant sections. The DuraSeal™ DBB Valve's variable zero leak rate ensures that maintenance, repair, leak locating, and hydrant testing can be done quickly and safely. Import/Export Facilities.
- **Offshore Platforms:** Secure shutoff is imperative on an offshore platform in that leakage can result in contamination of the water and possible equipment damage. The DuraSeal™ DBB Valve is the best choice for low pressure positive shutoff.
- **Blending Units:** The accurate blending of high-grade fuels requires valves of high sealing integrity to insure accurate addition of additives in blending operations.

Standard Materials of Construction

SERIES	D711 & D611 ANSI 150	D721 & D621 ANSI 300	D741 & D641 ANSI 600	D751 & D651 ANSI 900
BODY (1)(2)	CAST CARBON STEEL ASTM A216 WCB w/ CHROME PLATED BORE	CAST CARBON STEEL ASTM A216 WCB w/ CHROME PLATED BORE	CAST CARBON STEEL ASTM A216 WCB w/ CHROME PLATED BORE	CAST CARBON STEEL ASTM A216 WCB w/ CHROME PLATED BORE
BONNET/LOWER PLATE (2)	CARBON STEEL ASTM A216 WCB or ASTM A350 LF2	CARBON STEEL ASTM A216 WCB or ASTM A350 LF2	CARBON STEEL ASTM A216 WCB or ASTM A350 LF2	CARBON STEEL ASTM A216 WCB or ASTM A350 LF2
PLUG/STEM (2)	ASTM A216 WCB, ASTM A350 LF2 or ASTM A487-4D w/ ELECTROLESS NICKEL PLATING	ASTM A216 WCB, ASTM A350 LF2 or ASTM A487-4D w/ ELECTROLESS NICKEL PLATING	ASTM A216 WCB, ASTM A350 LF2 or ASTM A487-4D w/ ELECTROLESS NICKEL PLATING	ASTM A216 WCB, ASTM A350 LF2 or ASTM A487-4D w/ ELECTROLESS NICKEL PLATING
SLIPS (3)	DUCTILE IRON ASTM A536 GR. 60-40-18 or ASTM A395 60-40-18	DUCTILE IRON ASTM A536 GR. 60-40-18 or ASTM A395 60-40-18	DUCTILE IRON ASTM A536 GR. 60-40-18 or ASTM A395 60-40-18	DUCTILE IRON ASTM A536 GR. 60-40-18 or ASTM A395 60-40-18
GLAND	ASTM A182 F316	ASTM A182 F316	ASTM A182 F316	ASTM A182 F316
GLAND PACKING	GRAPHITE	GRAPHITE	GRAPHITE	GRAPHITE
BODY FIRE SEALS	STEEL or GRAPHITE	STEEL or GRAPHITE	STEEL or GRAPHITE	STEEL or GRAPHITE
O-RINGS & SLIP SEALS (4)	VITON* GF	VITON* GF	VITON* GF	VITON* GF
FASTENERS (5)	ASTM A193 GR. B7 / 2H	ASTM A193 GR. B7 / 2H	ASTM A193 GR. B7 / 2H	ASTM A193 GR. B7 / 2H

Note: All Materials subject to change without notice.

(1) ENP Bore available. (2) In Accordance with NACE MRO175 Latest Edition. (3) Manganese Phosphate Coating available. (4) See Additional Options Below.

(5) NACE Specification Available.

Proper seal selection requires a number of considerations such as media, pressure class, differential pressure, low temperature, high temperature, seal type, etc. To that end we have included a selection of slip seal materials and a brief list of considerations:

Fluoro Elastomers Slip Seal Materials (FKM)

FR	Fiber Reinforced	Optional HIDP, can be added to all Elastomer options upon request.
VGf	Viton* GF	Viton* with Enhanced Chem. Resistance, Our Standard Material
VGf9	Viton* 90 Durometer GF	HIDP Viton* GF
VGFLT	Viton* GFLT	Low Temp Viton* GF
VGFLT9	Viton* 90 Durometer GFLT	HIDP Low Temp Viton* GF
VE	Viton* ETP (Extreme)	Viton* with Chem. Resistance rivaling FFKM
VE9	Viton* 90 Durometer ETP	HIDP Viton* with Chem. Resistance rivaling FFKM

Pefluoro Elastomers Slip Seal Materials (FFKM)

KRZ	Kalrez*	Kalrez* with High Chem. Resistance
KRZ9	Kalrez* 90 Durometer	HIDP Kalrez*

All specifications and materials are subject to change without notice. DuraSeal™ conforms to API 6FA testing. Alternate seal materials may be provided upon request. *Generic equivalents provided

Preferred Mounting Positions

1.0 SCOPE OF INSTRUCTION

- 1.1 This information is provided for support of the DuraSeal™ Valve in maintaining the maximum life and function of the valve.
- 1.2 The contained information is subject to change without notice.
- 1.3 This document provides information for typical installations. In the event of unique situations, please contact your representative or the factory.

2.0 DEFINITIONS

- 2.1 **DBB** - Double Block and Bleed, method to test seat integrity with valve closed while under pressure.
- 2.2 **DIB-1** - Double Isolation and Bleed, Bi-Directional seating. API 6D definition of redundant sealing surfaces in both flow directions.
- 2.3 **DTR** - Differential Thermal Relief, provides the cavity relief functions of API 6D. Also contains DBB bleed function.

3.0 CONSIDERATIONS

- 3.1 Positioning of valve to provide operational access in installation. This is of particular concern for manually operated valves in pipe racks. Operator and handwheel extensions are available to improve access. See PUB-002-EN for details on the extension of DTR systems.
- 3.2 Positioning of DTR to provide proper function. The DTR relief direction should be toward the pressure side to be isolated. In a typical piping system, there is often a specific direction. When isolating equipment such as pumps, the preferred isolation may be different from the prevailing flow direction. See PUB-002-EN for DTR details.
- 3.3 Positioning of bleeds and drains to provide adequate operation. On valves which require complete draining, ensure that drains are positioned to provide complete draining. On valves which require DBB operation, it is typically preferable to position bleed valves for an elevated position so that DBB bleeds the minimum amount of liquid.
- 3.4 Positioning for reducing damage due to solids contained in fluids. With solids in the fluids, it is preferable to have regular draining of the body cavity to reduce accumulation and reduction of performance. It is also preferable to have the DTR to the upper side so that solids do not damage the DTR checks or valves.

4.0 PREFERRED MOUNTING POSITIONS

- 4.1 Positioning of the stem facing up in the vertical position is preferable.
- 4.2 700 Series: 12" or smaller 150 & 300 class and 6" or smaller 600 & 900 class may be oriented with a horizontal stem position.
- 4.3 600 Series: 10" or smaller 150 & 300 class and 4" or smaller 600 & 900 class may be oriented with a horizontal stem position.
- 4.4 If the valve is oriented with the stem in the horizontal position, it is preferable that the left flange is receiving the prevailing flow and that the DTR is on the upper side. This provides an inlet flow upon opening that tends to flush out any accumulated solids.
- 4.5 Mounting of the valve with the waterway oriented vertically is acceptable. This provides an inherent cavity flushing characteristic in both the upward and downward flow directions.
- 4.6 Mounting the valve with the stem facing down is non-preferred but may be acceptable for very clean conditions. This exposes the stem and stem seals to potential damage from settling solids and exposes the DTR to potential accumulations.

D700 SERIES REDUCED BORE – GEAR OPERATED

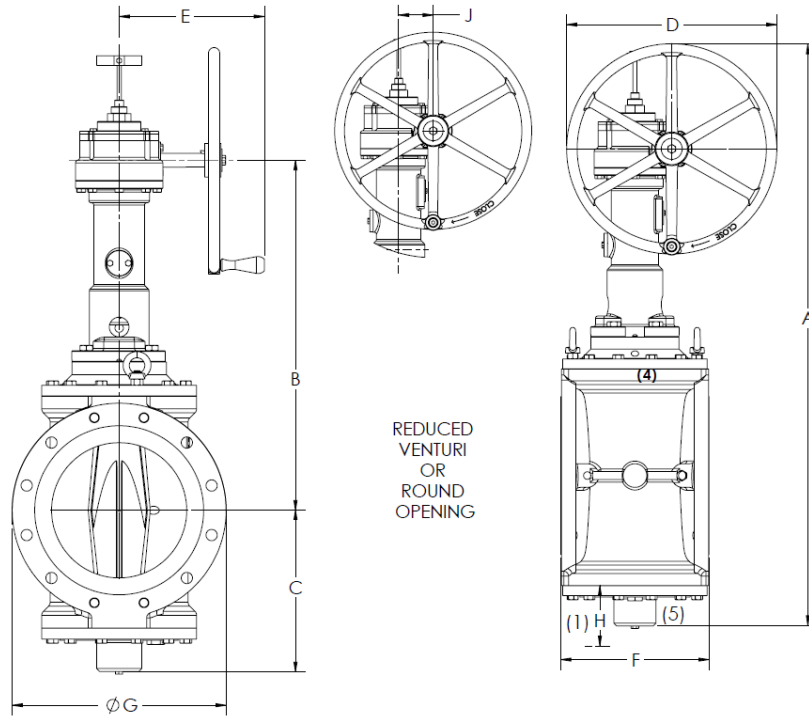

ANSI 150

SIZE	MODEL	OPER	A	B	C	D	E	F	G	H	J	WEIGHT (2)	(3)	(4)	(5)
2	D711	101	21	12	5	10	12	7	6	4	1 1/2	66	NONE	3/8" NPT	1/2" NPT
3	D711	101	21	12	4 1/2	10	11 1/2	8	7 1/2	4	1 1/2	76	NONE	3/8" NPT	1/2" NPT
4	D711	201	28	15	7	10	12	9	9	4 1/2	2	140	NONE	1/2" NPT	1/2" NPT
6	D711	301	37	20	9	14	13	10 1/2	11	8	3	302	(4) 3/4"-10UNC	1/2" NPT	1/2" NPT
8	D711	301	40	22	11	14	13	11 1/2	13 1/2	11	3	436	(4) 3/4"-10UNC	1/2" NPT	1/2" NPT
10	D711	301	42	23	12	14	13	13	16	14	3	532	(4) 7/8"-9UNC	1/2" NPT	1" NPT
12	D711	401	55 1/2	31	14 1/2	20	13	14	19	16	3 1/2	839	(4) 7/8"-9UNC	1/2" NPT	1" NPT
14	D711	401	58 1/2	32	16	20	13	15	21	19	3 1/2	1074	(4) 1"-8UNC	1/2" NPT	1" NPT
16	D711	501	67	39	18 1/2	20	14 1/2	16	23 1/2	21	5	1488	(8) 1"-8UNC	1/2" NPT	1" NPT
18	D711	501	67	39	18	20	14 1/2	17	25	21	5	1600	(8) 1-1/8"-8UNC	1/2" NPT	1" NPT
20V	D711	501	75 1/2	40	25	20	14 1/2	32	27 1/2	35	5	2700	NONE	1/2" NPT	1" NPT
24	D711	501	78 1/2	44	24 1/2	20	14 1/2	48	32	20	5	6350	NONE	1/2" NPT	1" NPT
24V	D711	501	83	44	30	20	14 1/2	36	32	42	5	4300	NONE	1/2" NPT	1" NPT
30	D711	601	103	56	31	32	21	60	38 3/4	35	9	13300	NONE	1/2" NPT	1" NPT
30V	D711	601	105	57	33	32	21	60	38 3/4	32	9	9800	NONE	1/2" NPT	1" NPT
36	D711	701	132	78	38	32	20	78	46	55	9	15660	NONE	1/2" NPT	1" NPT

- (1) H-Minimum clearance required to replace slips.
- (2) Approximate Weights (Lbs.).
- (3) Number and size tapped holes.
- (4) Tapped bleeder hole.

- (5) Bottom plate drain hole.
- (6) Contact factory for size requirements not listed.
- (7) Dimensions are not certified. Contact factory for certified drawings.

- (8) Consult factory for additional sizes.
- (9) Dimensions "E", "F", "G" & "J" are nominal. All others are rounded off to the nearest half-inch.

D700 SERIES REDUCED BORE ANSI 300, 600, 900- GEAR OPERATED

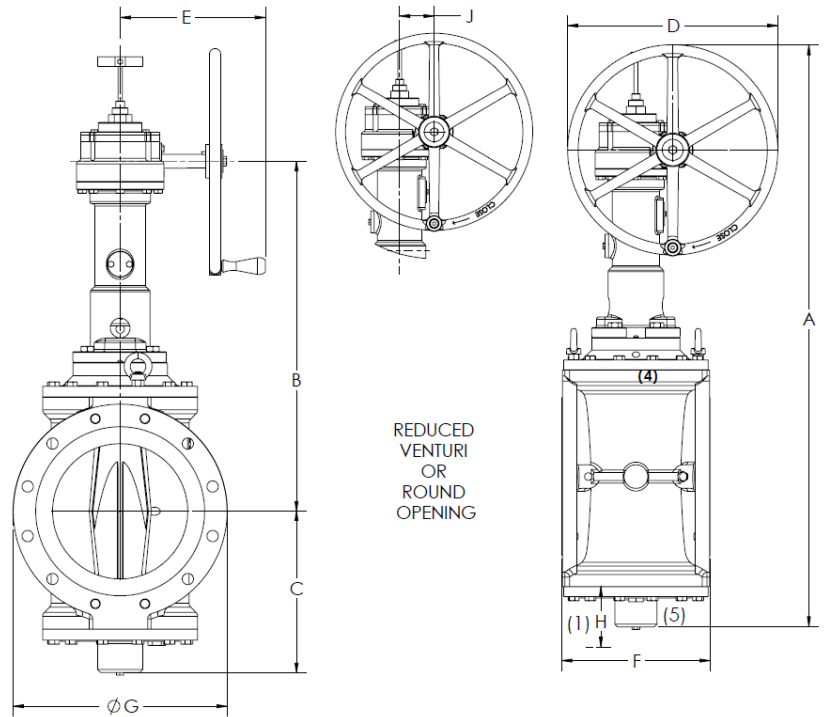

ANSI SIZE	MODEL	OPER	A	B	C	D	E	F	G	H	J	WEIGHT (2)	(3)	(4)	(5)	
300	2	D721	101	21	12	4 1/2	10	11 1/2	8 1/2	6 1/2	4	1 1/2	78	NONE	3/8" NPT	1/2" NPT
	3	D721	101	21	12	4 1/2	10	11 1/2	11 1/8	8 1/4	4	1 1/2	102	NONE	3/8" NPT	1/2" NPT
	4	D721	201	27 1/2	15	7	10	11	12	10	4 1/2	1 3/4	162	NONE	1/2" NPT	1/2" NPT
	6	D721	301	37	20 1/2	9	14	12 1/2	15 7/8	12 1/2	8	3	348	NONE	1/2" NPT	1/2" NPT
	8	D721	401	50	28	11 1/2	20	13	16 1/2	15	11	3 1/2	666	(4) 7/8"-9UNC	1/2" NPT	1/2" NPT
	10	D721	401	52	29	13	20	13	18	17 1/2	13	3 1/2	888	(4) 1"-8UNC	1/2" NPT	1/2" NPT
	12	D721	501	64	36 1/2	17	20	14 1/2	19 3/4	20 1/2	16	5	1414	(8) 1-1/8"-8UNC	1/2" NPT	1" NPT
	14	D721	501	60	35	14 1/2	20	14 1/2	30	23	12	5	1850	NONE	1/2" NPT	1" NPT
	16	D721	501	69	38	21	20	14 1/2	33	25 1/2	15	5	3400	(8) 1-1/4"-8UNC	1/2" NPT	1" NPT
	18	D721	501	69	38	21	20	14 1/2	36	28	15	5	3500	(8) 1-1/4"-8UNC	1/2" NPT	1" NPT
20	D721	601	85	46	23	32	21	39	30 1/2	17	9	5000	NONE	1/2" NPT	1" NPT	
24	D721	601	93	51	26	32	21	52	36	24	9	9525	NONE	1/2" NPT	1" NPT	
600	2	D741	201	25	14 1/2	5 1/2	10	11	11 1/2	6 1/2	3	1 3/4	100	NONE	1/2" NPT	1/2" NPT
	3	D741	201	26	15	6	10	11	14	8 1/4	3 1/2	1 3/4	142	NONE	1/2" NPT	1/2" NPT
	4	D741	301	33 1/2	19	7 1/2	14	12 1/2	17	10 3/4	4	3	230	NONE	1/2" NPT	1/2" NPT
	6	D741	401	45 1/2	26	9	20	13	22	14	10	3 1/2	700	NONE	1/2" NPT	1/2" NPT
	8	D741	401	48	27	11	20	13	26	16 1/2	12	3 1/2	1102	NONE	1/2" NPT	1/2" NPT
	10	D741	501	56 1/2	33 1/2	13	20	14 1/2	31	20	8	5	1974	NONE	1/2" NPT	1" NPT
	12	D741	501	60	35	15	20	14 1/2	33	22	10	5	2500	NONE	1/2" NPT	1" NPT
	14	D741	501	60	35	14	20	14 1/2	35	23 3/4	11	5	2500	NONE	1/2" NPT	1" NPT
	16	D741	601	83	44	23	32	21	39	27	15	9	4700	NONE	1/2" NPT	1" NPT
	18	D741	601	83	44	23	32	21	43	29 1/4	15	9	5000	NONE	1/2" NPT	1" NPT
20	D741	701	108	66	26	32	20	47	32	15	9	9350	NONE	1/2" NPT	1" NPT	
900	2	D751	301	33	18	8	14	12 1/2	14 1/2	8 1/2	10	3	265	NONE	1/2" NPT	1/2" NPT
	3	D751	301	32	18	7	14	13	15	9 1/2	10	3	290	NONE	1/2" NPT	1/2" NPT
	4	D751	401	47	26 1/2	11	20	13	18	11 1/2	12	3 1/2	800	(4) 1-1/8"-7UNC	1/2" NPT	1/2" NPT
	6	D751	401	47 1/2	26 1/2	11	20	13	24	15	12	3 1/2	905	NONE	1/2" NPT	1/2" NPT
	8	D751	501	59	34 1/2	15	20	14 1/2	29	18 1/2	15	5	1750	NONE	1/2" NPT	1/2" NPT
	10	D751	601	74 1/2	42 1/2	16	32	21	33	21 1/2	10	9	3000	NONE	1/2" NPT	1" NPT

(1) H-Minimum clearance required to replace slips.
 (2) Approximate Weights (Lbs.).
 (3) Number and size tapped holes.
 (4) Tapped bleeder hole.

(5) Bottom plate drain hole.
 (6) Contact factory for size requirements not listed.
 (7) Dimensions are not certified. Contact factory for certified drawings.

(8) Consult factory for additional sizes.
 (9) Dimensions "E", "F", "G" & "J" are nominal. All others are rounded off to the nearest half-inch.

D700 SERIES HANDWHEEL OPERATED

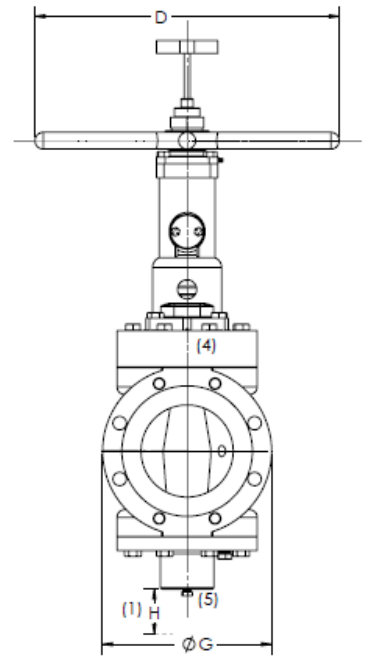
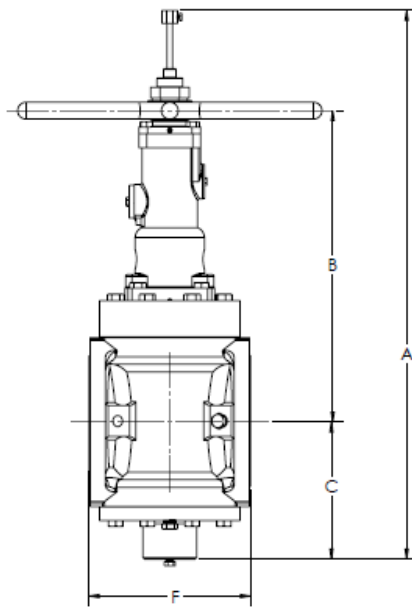

ANSI	SIZE	MODEL	OPER	A	B	C	D	F	G	H	WEIGHT (2)	(3)	(4)	(5)
150	2	D711	100	19	10 1/2	4 1/2	11	7	6	4	48	NONE	3/8" NPT	1/2" NPT
	3	D711	100	19	10 1/2	4 1/2	11	8	7 1/2	4	70	NONE	3/8" NPT	1/2" NPT
	4	D711	200	28	16	7	20	9	9	4 1/2	140	NONE	1/2" NPT	1/2" NPT
	6	D711	300	36	20	9	20	10 1/2	11	8	270	(4) 3/4"-10UNC	1/2" NPT	1/2" NPT
300	2	D721	100	19	10 1/2	4 1/2	11	8 1/2	6 1/2	4	54	NONE	3/8" NPT	1/2" NPT
	3	D721	100	19	10 1/2	4 1/2	11	11 1/8	8 1/4	4	102	NONE	3/8" NPT	1/2" NPT
	4	D721	200	28	16	7	20	12	10	4 1/2	158	NONE	1/2" NPT	1/2" NPT
	6	D721	300	34	20 1/2	9 1/2	20	15 7/8	12 1/2	8	348	NONE	1/2" NPT	1/2" NPT
600	2	D741	200	26	15	5 1/2	20	11 1/2	6 1/2	3	100	NONE	1/2" NPT	1/2" NPT
	3	D741	200	27	16	6 1/2	20	14	8 1/4	3 1/2	142	NONE	1/2" NPT	1/2" NPT
	4	D741	300	33	19	7 1/2	20	17	10 3/4	4	230	NONE	1/2" NPT	1/2" NPT

- (1) H-Minimum clearance required to replace slips.
- (2) Approximate Weights (Lbs.).
- (3) Number and size tapped holes.
- (4) Tapped bleeder hole.

- (5) Bottom plate drain hole.
- (6) Contact factory for size requirements not listed.
- (7) Dimensions are not certified. Contact factory for certified drawings.

- (8) Consult factory for additional sizes.
- (9) Dimensions "F" & "G" are nominal. All others are rounded off to the nearest half-inch.

D600 SERIES FULL BORE - GEAR OPERATED



ANSI 150

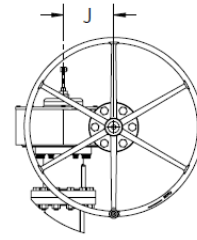
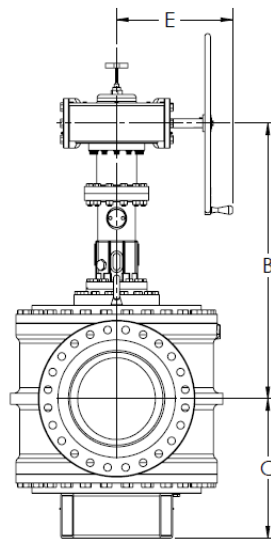

FULL BORE
OPENING

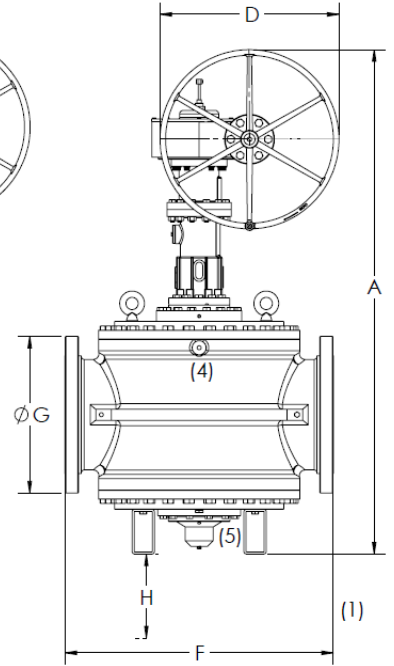

SIZE	MODEL	OPER	A	B	C	D	E	F	G	H	J	WEIGHT (2)	(3)	(4)	(5)
2	D611	201	27	15	7	10	12	10 1/2	6	7	2	147	NONE	1/2" NPT	1/2" NPT
3	D611	201	27	15	7	10	12	13 1/2	7 1/2	7	2	154	NONE	1/2" NPT	1/2" NPT
4	D611	301	37	20	10	14	13	17	9	12	3	262	NONE	1/2" NPT	1/2" NPT
6	D611	401	48	27	11	20	12	21	11	15	3 1/2	515	NONE	1/2" NPT	1/2" NPT
8	D611	401	50	28	12	20	12	25	13 1/2	14	3 1/2	964	NONE	1/2" NPT	1/2" NPT
10	D611	501	60	35	15	20	15	31	16	13	5	1658	NONE	1/2" NPT	1" NPT
12	D611	501	69	38	21	20	15	36	19	15	5	3000	NONE	1/2" NPT	1" NPT
14	D611	501	69	38	21 1/2	20	14 1/2	34	21	15	5	3000	NONE	1/2" NPT	1" NPT
16	D611	501	67	37	20	20	14 1/2	35	23 1/2	17	5	3250	NONE	1/2" NPT	1" NPT
18	D611	501	78	43	25	20	14 1/2	48	25	26	5	5750	NONE	1/2" NPT	1" NPT
20	D611	501	77	43	24	20	14 1/2	48	27 1/2	24	5	6264	NONE	1/2" NPT	1" NPT
24	D611	601	102 1/2	56	30 1/2	32	21	60	32	35	9	13300	NONE	1/2" NPT	1" NPT

- (1) H-Minimum clearance required to replace slips.
- (2) Approximate Weights (Lbs.).
- (3) Number and size tapped holes.
- (4) Tapped bleeder hole.

- (5) Bottom plate drain hole.
- (6) Contact factory for size requirements not listed.
- (7) Dimensions are not certified. Contact factory for certified drawings.

- (8) Consult factory for additional sizes.
- (9) Dimensions "E", "F", "G" & "J" are nominal. All others are rounded off to the nearest half-inch.

D600 SERIES FULL BORE ANSI 300, 600, 900 - GEAR OPERATED

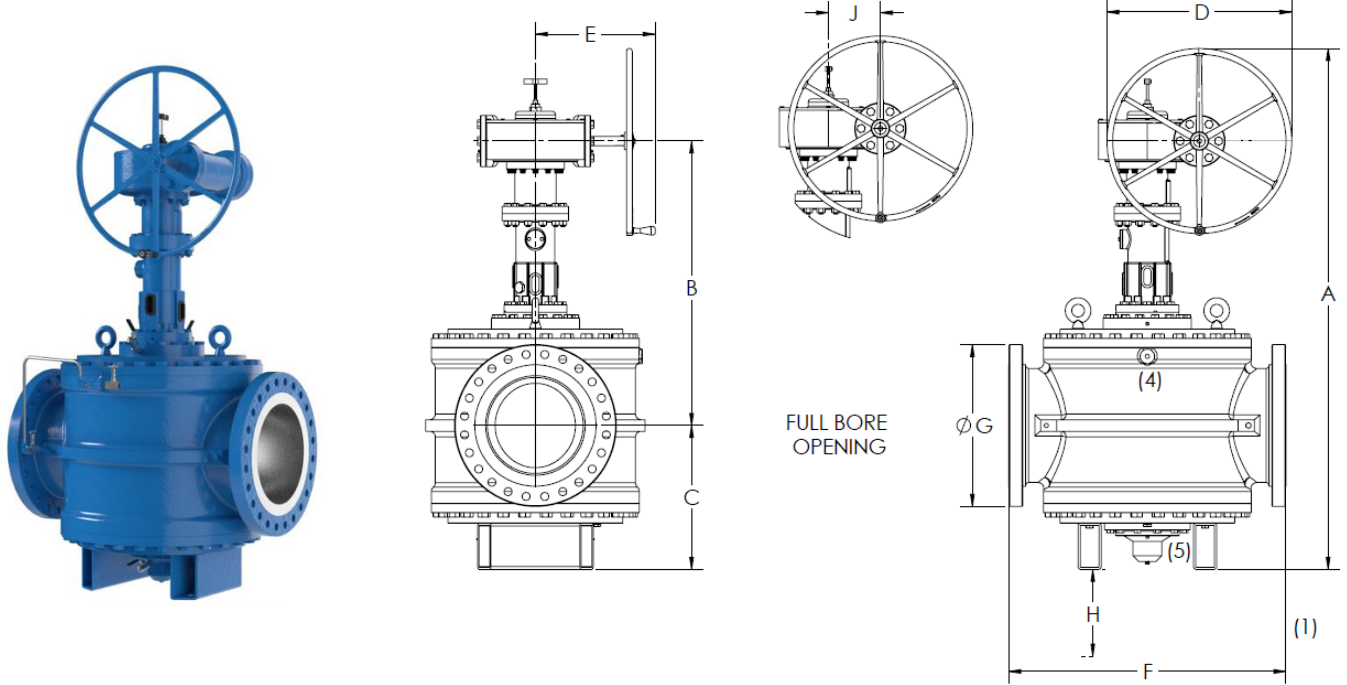

ANSI	SIZE	MODEL	OPER	A	B	C	D	E	F	G	H	J	WEIGHT (2)	(3)	(4)	(5)
300	2	D621	201	27	15	6	10	11	11 1/8	6 1/2	7	2	151	NONE	1/2" NPT	1/2" NPT
	3	D621	201	27	15	7	10	11	15	8 1/4	7	2	164	NONE	1/2" NPT	1/2" NPT
	4	D621	301	29	20	9	14	13	18	10	12	3	391	NONE	1/2" NPT	1/2" NPT
	6	D621	401	49	27	11	20	13	22	12 1/2	15	3 1/2	553	NONE	1/2" NPT	1/2" NPT
	8	D621	401	50	28	12	20	13	27	15	14	3 1/2	1003	NONE	1/2" NPT	1/2" NPT
	10	D621	501	60	35	15	20	14 1/2	32 1/2	17 1/2	13	5	1720	NONE	1/2" NPT	1" NPT
	12	D621	501	68	38	21	20	14 1/2	38	20 1/2	15	5	3000	NONE	1/2" NPT	1" NPT
	14	D621	501	69	38	21	20	14 1/2	34	23	15	5	3225	(8) 1-1/8"-8UNC	1/2" NPT	1" NPT
	16	D621	601	85	46	23	32	21	35	25 1/2	17	9	4590	NONE	1/2" NPT	1" NPT
18	D621	601	90	49	25	32	21	48	28	26	9	7080	NONE	1/2" NPT	1" NPT	
600	2	D641	201	27	15	7	10	11	13	6 1/2	7	2	165	NONE	1/2" NPT	1/2" NPT
	3	D641	201	27	15	7	10	11	17 1/2	8 1/4	7	2	183	NONE	1/2" NPT	1/2" NPT
	4	D641	401	46	26	9	20	13	17	10 3/4	10	3 1/2	500	(4) 7/8"-9UNC	1/2" NPT	1/2" NPT
	6	D641	401	48	27	11	20	13	22	14	12	3 1/2	671	(4) 1"-8UNC	1/2" NPT	1/2" NPT
	8	D641	501	57	33	13	20	14 1/2	26	16 1/2	8	5	1681	(4) 1-1/8"-7UNC	1/2" NPT	1/2" NPT
	10	D641	501	60	35	14	20	14 1/2	31	20	11	5	2200	NONE	1/2" NPT	1" NPT
	12	D641	601	83	44	23	32	14 1/2	33	22	15	9	4200	NONE	1/2" NPT	1" NPT
16	D641	701	108	66	26	32	20	39	27	15	9	8500	(8) 1-1/2"-8UNC	1/2" NPT	1" NPT	
900	2	D651	301	32	18	7	14	13	15	8 1/2	3	3	285	NONE	1/2" NPT	1/2" NPT
	3	D651	401	47	26	11	20	13	18 1/2	9 1/2	6	3 1/2	800	(4) 7/8"-9UNC	1/2" NPT	1/2" NPT
	4	D651	401	48	27	11	20	13	22	11 1/2	12	3 1/2	796	NONE	1/2" NPT	1/2" NPT
	6	D651	501	59	34	15	20	14	29	15	15	5	1621	NONE	1/2" NPT	1/2" NPT
	8	D651	601	74	43	16	32	21	32	18 1/2	10	9	2654	NONE	1/2" NPT	1/2" NPT

(1) H-Minimum clearance required to replace slips.

(2) Approximate Weights (Lbs.).

(3) Number and size tapped holes.

(4) Tapped bleeder hole.

(5) Bottom plate drain hole.

(6) Contact factory for size requirements not listed.

(7) Dimensions are not certified. Contact factory for certified drawings.

(8) Consult factory for additional sizes.

(9) Dimensions "E", "F", "G" & "J" are nominal. All others are rounded off to the nearest half-inch.

EXTENSION KITS

Franklin makes available both vertical and lateral extensions. In ordering, always specify dimensions

B or E. Type A extension is suitable for underground burial. Type C extension should be supported if dimension E is over 36".

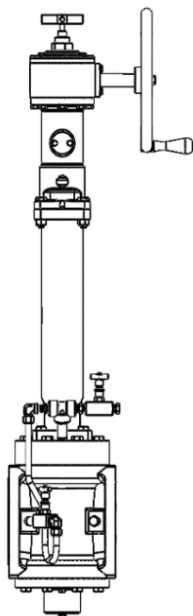

GEAR OPERATOR
EXTENSION-CLOSED
TYPE "A"

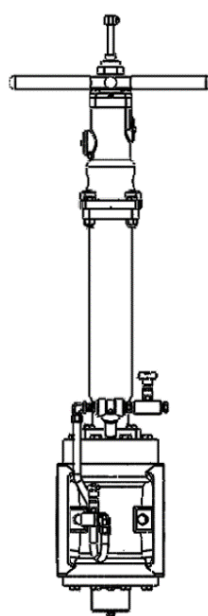

HAND OPERATOR
EXTENSION-CLOSED
TYPE "A"

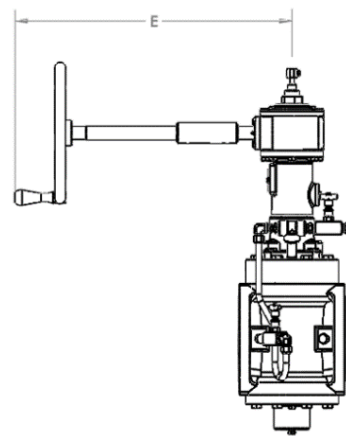

GEAR OPERATOR
EXTENSION-LATERAL
TYPE "C"

ELECTRIC MOTOR ACTUATION

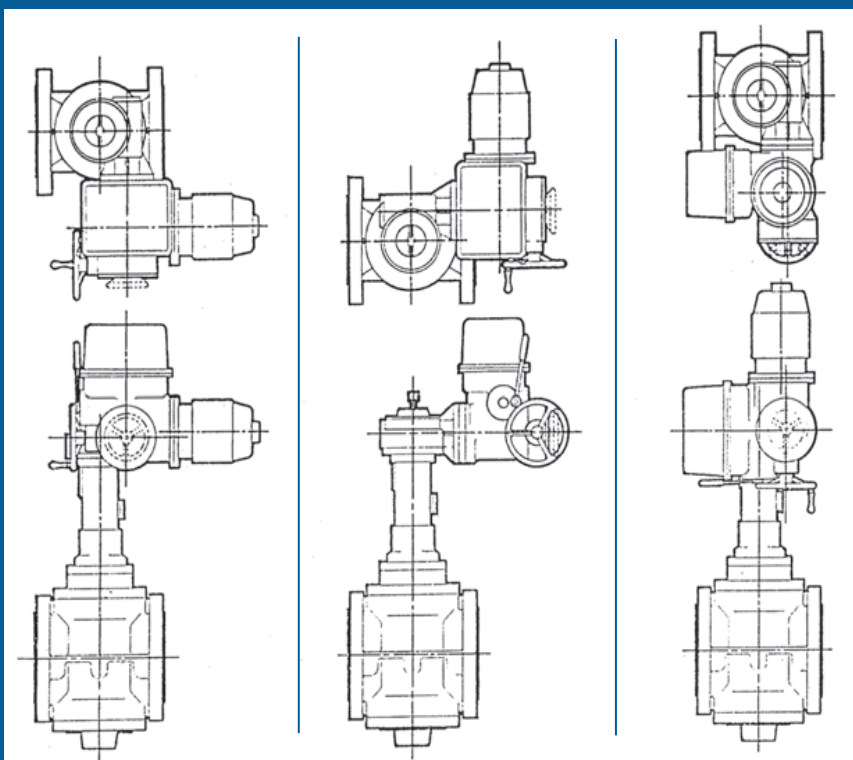

STYLE "A"
(Standard mounting)
MOTOR OPERATOR
MOUNTED PARALLEL
TO PIPE LINE

STYLE "B"
MOTOR OPERATOR
MOUNTED AT RIGHT
ANGLE TO PIPE LINE

STYLE "C"
MOTOR OPERATOR
MOUNTED VERTICAL
TO PIPE LINE

WHEN ORDERING ELECTRIC MOTOR OPERATORS, SPECIFY THE FOLLOWING:

INSTALLATION

1. Mounting style
2. Valve installation attitude (for proper location of breathers and drains)

TYPE OF VALVE

3. Valve figure number
4. Size
5. ANSI rating

OPERATING CONDITIONS

6. Differential pressure in PSI
7. Operating time in seconds

ELECTRICAL DATA

8. Explosion proof NEMA VII or weatherproof NEMA IV
9. Phase, Cycle, Volts - controls and motors

SPECIAL FEATURES

10. Gear limit switch (2 or 4 train)
11. Reversing controller (if separate, it is to be explosion proof NEMA VII, or weatherproof)
12. Breather or drains, if desired
13. Space heater, if desired
14. Control transformer, if desired (specify voltage)
15. Other special requirements

D700 SERIES ANSI 150

VALVE	OPERATOR	TORQUE FT -LBS.	TORQUE KG-M	TURNS	Cv	Kv
2" 150# D711	100 HWO	15	2.07	1.8	195	169
2" 150# D711	101 Gear	2.4	0.3	15		
3" 150# D711	100 HWO	15	2.07	2	200	173
3" 150# D711	101 Gear	6	0.83	15		
4" 150# D711	200 HWO	25	3.46	2.7	530	458
4" 150# D711	201 Gear	7	0.97	17		
6" 150# D711	300 HWO	30	4.15	2.7	1415	1224
6" 150# D711	301 Gear	19	2.63	20		
8" 150# D711	301 Gear	41	5.7	21.5	2400	2076
10" 150# D711	301 Gear	66	9.1	22	3500	3028
12" 150# D711	401 Gear	90	12.4	25.5	4000	3460
14" 150# D711	401 Gear	92	12.7	25	5500	4758
16" 150# D711	501 Gear	104	14.4	45	6600	5709
18" 150# D711	501 Gear	104	14.4	47.5	6600	5709
20" 150# D711 (20x16)	501 Gear	158	21.8	51	15700	13581
20" 150# D711RVP	501 Gear	160	22.1	52	16000	13840
24" 150# D711 (24x20)	501 Gear	167	23.1	53	24000	20760
24" 150# D711RVP	501 Gear	200	27.65	54		
30" 150# D711 (30x25)	601 Gear	250	34.6	70	33000	28545
30" 150# D711RVP	601 Gear	240	33.2	52.5	44500	38493
36" 150# D711	701 Gear	315	43.6	63	48000	41520

Cv US gallons per minute of flow with 60 degrees F water at 1 PSI pressure drop in the fully open position

Kv is cubic meters Per hours of flow with 16 degrees C water at 1 Bar pressure drop in the fully open position

* All values subject to change, reference PUB-005-EN for up-to-date values.

D700 SERIES ANSI 300/600/900

VALVE	OPERATOR	TORQUE FT -LBS.	TORQUE KG-M	TURNS	Cv	Kv
2" 300# D721	100 HWO	30	4.15	1.8	205	177
2" 300# D721	101 Gear	6	0.83	16		
2" 600# D741	200 HWO	25	3.46	2	290	251
2" 600# D741	201 Gear	19	2.63	14		
2" 900# D751 (2x1.5)	301 Gear	30	4.15	13	160	138.4
3" 300# D721	100 HWO	30	4.15	1.8	210	182
3" 300# D721	101 Gear	6	0.83	15		
3" 600# D741	200 HWO	55	7.60	2	300	260
3" 600# D741	201 Gear	28	3.87	15		
3" 900# D751	301 Gear	65	8.99	13	250	216.25
4" 300# D721	200 HWO	64	8.85	2.7	570	493
4" 300# D721	201 Gear	38	5.25	17		
4" 600# D741	300 HWO	150	20.74	2.75	850	735
4" 600# D741	301 Gear	38	5.25	16		
4" 900# D751 (4x3)	401 Gear	138	19.08	24	650	562.25
6" 300# D721	300 HWO	120	16.59	2.7	1770	1531
6" 300# D721	301 Gear	60	8.30	20		
6" 600# D741	401 Gear	117	16.2	25	2265	1959
6" 900# D751 (6x5)	401 Gear	120	16.59	24	2265	1959
8" 300# D721	401 Gear	105	14.52	24.5	3000	2595
8" 600# D741	401 Gear	125	17.3	25.5	3600	3114
8" 900# D751	501 Gear	145	20.05	32	4200	3633
10" 300# D721	401 Gear	138	19.1	27.5	3540	3062
10" 600# D741	501 Gear	185	25.6	40	5100	4412
10" 900# D751	601 Gear	300	41.48	34	5500	4757.5
12" 300# D721	501 Gear	184	25.44	41	4700	4066
12" 600# D741	501 Gear	219	30.3	33	9200	7958
14" 300# D721 (14x10)	501 Gear	130	17.97	36	9200	7958
14" 600# D741	501 Gear	220	30.42	34	9200	7958
16" 300# D721 (16x12)	501 Gear	230	31.80	64.5	12000	10380
16" 600# D741	601 Gear	350	48.4	70	12000	10380
18" 300# D721 (18x12)	501 Gear	230	31.80	64.5	12000	10380
18" 600# D741	601 Gear	350	48.4	70	12000	10380
20" 300# D721 (20x16)	601 Gear	305	42.17	52.5	16300	14100
20" 600# D741	701 Gear	550	76.0	56	16500	14273
24" 300# D721	601 Gear	400	55.30	56	27000	23355

Cv US gallons per minute of flow with 60 degrees F water at 1 PSI pressure drop in the fully open position

Kv is cubic meters Per hours of flow with 16 degrees C water at 1 Bar pressure drop in the fully open position

* All values subject to change, reference PUB-005-EN for up to date values.

D600 SERIES ANSI 150/300/600/900

VALVE	OPERATOR	TORQUE FT-LBS.	TORQUE KG-M	TURNS
2" 150# D611	201 Gear	7	0.97	13
2" 300# D621	201 Gear	14	1.94	13
2" 600# D641	201 Gear	28	3.87	13
2" 900# D651	301 Gear	65	8.99	13
3" 150# D611	201 Gear	7	0.97	13
3" 300# D621	201 Gear	14	1.94	13
3" 600# D641	201 Gear	28	3.87	13
3" 900# D651	401 Gear	138	19.08	24
4" 150# D611	301 Gear	19	2.63	20
4" 300# D621	301 Gear	60	8.30	20
4" 600# D641	401 Gear	117	16.18	29
4" 900# D651	401 Gear	120	16.59	24
6" 150# D611	401 Gear	40	5.53	21
6" 300# D621	401 Gear	90	12.44	21
6" 600# D641	401 Gear	125	17.28	22
6" 900# D651	501 Gear	145	20.04	32
8" 150# D611	401 Gear	125	17.28	23
8" 300# D621	401 Gear	200	27.65	26
8" 600# D641	501 Gear	185	25.58	33
8" 900# D651	601 Gear	300	41.48	34
10" 150# D611	501 Gear	120	16.59	31
10" 300# D621	501 Gear	219	30.28	31
10" 600# D641	501 Gear	220	30.42	34
12" 150# D611	501 Gear	160	22.12	64
12" 300# D621	501 Gear	230	31.80	64
12" 600# D641	601 Gear	350	48.39	70
14" 150# D611	501 Gear	140	19.36	64.5
14" 300# D621	501 Gear	230	31.80	64.5
16" 150# D611	501 Gear	158	21.84	45.5
16" 300# D621	601 Gear	305	42.17	52
16" 600# D651	701 Gear	550	76.04	56
18" 150# D611	501 Gear	185	25.58	50
18" 300# D621	601 Gear	350	48.39	54
20" 150# D611	501 Gear	167	23.09	53
24" 150# D611	601 Gear	250	34.56	70

GEAR OPERATOR MOUNTING

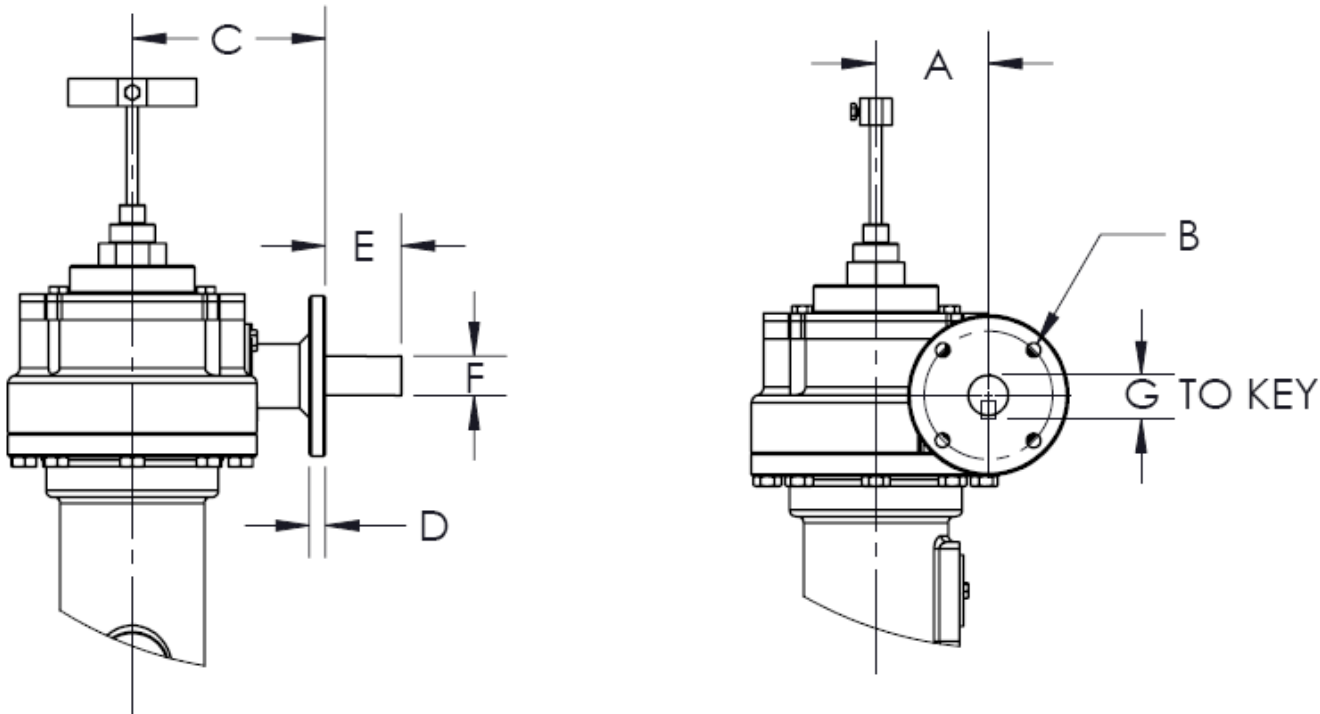

- SHOWN WITH STANDARD SHAFTS. CONTACT FACTORY FOR NONSTANDARD CONFIGURATIONS.
- WGA MAY BE FIELD REPOSITIONED IN 90 INCREMENTS ON STEM CL.

Model	A	ADAPTER	B-BOLT PATTERN	C	D	E	F	G
101	1-1/2	29-101	FA10: 4X 0.440 ON 4.0 BCD	5.4	0.50	2.0	0.745/0.740 W/KEYWAY 3/16 x 1.00	0.823/0.833
201	1-3/4	29-3001	FA10: 4X 0.440 ON 4.0 BCD	5.4	0.50	2.3	0.868/0.866 W/KEYWAY 5/16 x 1.00	1.069/1.081
301	3	29-1000	FA10: 4X 0.440 ON 4.0 BCD	6.0	0.50	2.4	1.250/1.245 W/KEYWAY 5/16 x 1.12	1.418/1.441
		29-2000	FA14: 4X 0.688 ON 5.5 BCD	6.0	0.63	2.4		
		29-2002	FA16: 4X 0.800 ON 6.5 BCD	6.0	0.63	2.4		
401	3-1/2	29-1000	FA10: 4X 0.440 ON 4.0 BCD	6.0	0.50	2.4		
		29-2000	FA14: 4X 0.688 ON 5.5 BCD	6.0	0.63	2.4		
		29-2002	FA16: 4X 0.800 ON 6.5 BCD	6.0	0.63	2.4		
501	5	29-3000	FA10: 4X 0.400 ON 4.0 BCD	7.6	0.50	2.4		
		29-501	FA14: 4X 0.688 ON 5.5 BCD	8.0	1.05	2.4		
		29-3002	FA16: 4X 0.812 ON 6.5 BCD	8.0	1.05	2.4		
		29-501-FA25	FA25: 8X 0.688 ON 10.0 BCD	8.0	1.05	2.4		
601	9	29-601-FA25	FA25: 8X 0.688 ON 10.0 BCD	14.0	1.00	2.2	1.627/1.622 W/KEYWAY 3/8 x 2.12	1.777/1.787
		29-601-FA16	FA16: 4X 0.812 ON 6.5 BCD	14.0	0.63	2.2		
701	9	29-601-FA25	FA25: 8X 0.688 ON 10.0 BCD	14.0	1.00	2.2	1.627/1.622 W/KEYWAY 3/8 x 2.12	1.777/1.787
		29-601-FA16	FA16: 4X 0.812 ON 6.5 BCD	14.0	0.63	2.2		

- Values subject to change, reference SK-0014 for the most up to date values.

The DuraSeal™ Valve is by Design a Bidirectional DIB-1 Valve:

This design has inherent characteristics of trapping body cavity pressure. Because valves in liquid or condensing service can have a thermal hydraulic expansion within the trapped cavity, API 6D requires a cavity pressure relief system. The valves on the configurations permit different directionality characteristics.

These configurations relate to the operational reliefs and DBB operation. The lower body bleeds are not addressed in this document, but should be used as necessary to eliminate line solids from accumulating under the plug.

For the following configurations, the left flange (when facing the piping of an upright valve) is the upstream flange. For installations with clearance issues, a reverse DTR may be ordered which provides the right flange as the upstream flange.

The upstream flange is the flange of preferred pressure isolation. Depending upon the required isolation, the valve preferred pressure direction may not be the direction of flow. For applications where a piece of equipment is being isolated from the piping, the preferred pressure isolation will typically be the flange away from the equipment.

Extending of the Body Bleed Outlets: For convenient bleed positions, the body bleed outlets may be extended from the NPT outlet of the manual bleed valve. This shall retain the original bleed valve for interim isolation.

Standard DTR



Optional Line Relieving DTR



Automatic Body Bleed DTR



Standard Differential Thermal Relief (DTR)

This configuration is acceptable for liquid service.

The BODY BLEED VALVE is only for the purposes of manually venting the body cavity and DBB testing.

When not being used for bleeding, the body bleed valve should be closed and the outlet should be plugged.

The UPSTREAM ISOLATION VALVE must be left open for cavity relief to function.

It should only be closed for maintenance and leakage management in the event of damage.

Directionality Characteristics of Valve Are Shown Below

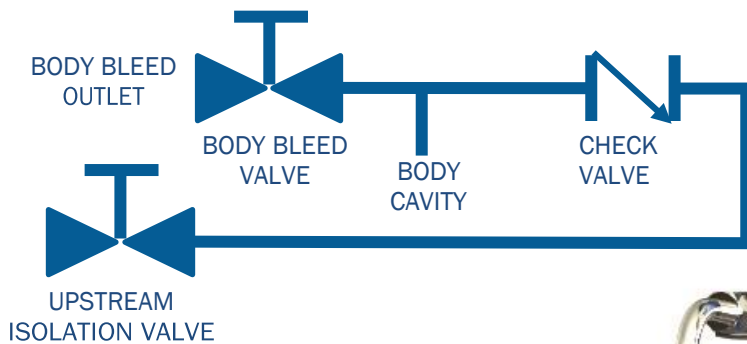

Optional Line Relieving Differential Thermal Relief (LRDTR)

This configuration may be used to relieve trapped piping downstream from the valve. Downstream isolation valve must be closed for DBB confirmation.

When not being used for bleeding, the body bleed valve should be closed and the outlet should be plugged.

Directionality Characteristics of Valve Are Shown Below

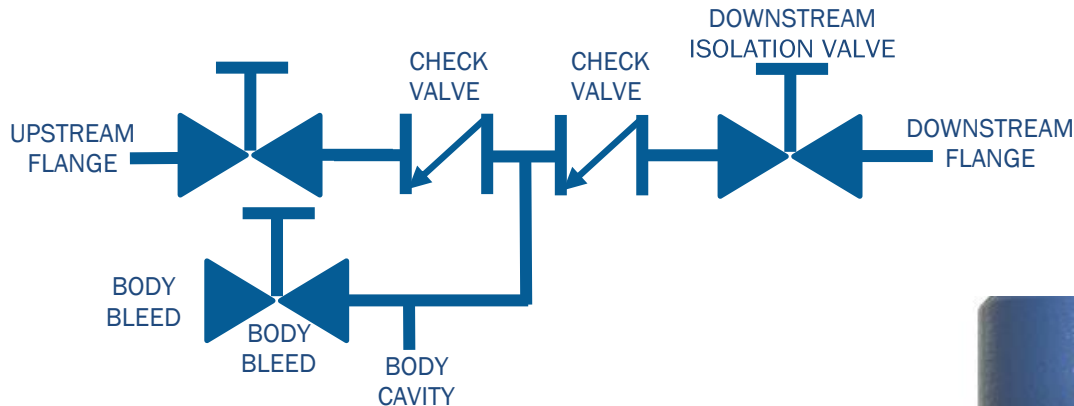

Automatic Body Bleed Differential Thermal Relief (ABBVDTR)

This configuration allows for automatic venting of body cavity pressure to an external customer designated location upon closure of the valve.

This allows for visual confirmation of seal integrity as well as preventing thermal expansion in the valve cavity.

The bleed valve is actuated by the operator mechanism, opening when the DuraSeal™ is seated, and closing once the DuraSeal™ begins to travel open.

The needle valve should remain open during operation and should only be closed for maintenance and leak management in the event of damage.

Directionality Characteristics of Valve Are Shown Below

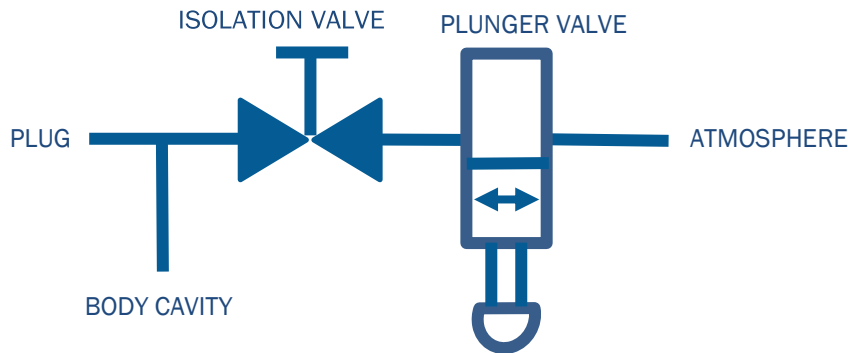



 500 Northpark Central Dr. Suite 100 Houston, Texas 77073

 713.812.7100

 sales@franklinvalve.com

 franklinvalve.com

 www.linkedin.com/franklin-valve-lp

